

| BILL OF MATERIAL | | | |
|------------------|----------------|---|-------------------|
| ITEM NUMBER | CATALOG NUMBER | DESCRIPTION | QUANTITY REQUIRED |
| ① | FSRM-12 | 1/2"-13 DROP-IN ANCHOR Material: 18-8 STAINLESS STEEL | 7 |
| ② | FFW316-18-40 | FLAT WASHER ID=.562, OD=1.250, THK=.078 Material: 316 STAINLESS STEEL | 7 |
| ③ | FHC316-16-044 | 1/2"-13 X 1-3/8" LG. HEX HEAD CAP SCREW Material: 316 STAINLESS STEEL | 7 |
| ④ | CR48-B | CR48-B STANCHION Material: 50% Glass Reinforced Nylon | 1 |
| ⑤ | 4.9HDS | 4.9HDS SADDLE Material: 50% Glass Reinforced Nylon | 1 |
| ⑥ | RA08 | RA08 ARM (8" LONG) Material: 50% Glass Reinforced Nylon | 1 |
| ⑦ | RA14-LP | RA14-LP ARM (14" LONG) Material: 50% Glass Reinforced Nylon | 1 |
| ⑧ | RA20-LP | RA20-LP ARM (20" LONG) Material: 50% Glass Reinforced Nylon | 2 |
| ⑨ | HDL | HDL LOCK (OPTIONAL) Material: Polycarbonate | 1 PER ARM |
| NOT SHOWN | FRT-112 | SETTING TOOL (Used to install Catalog No. FSRM-12 Drop-In Anchor) | AS REQ'D |

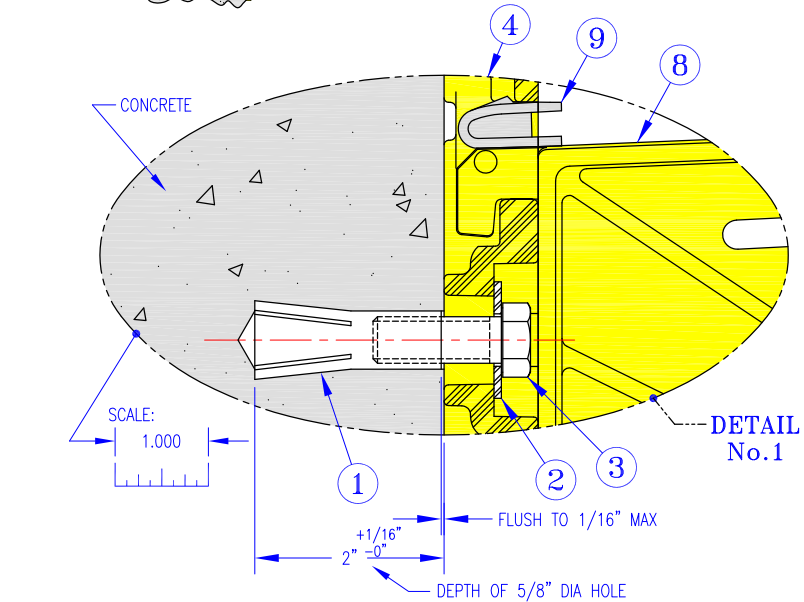
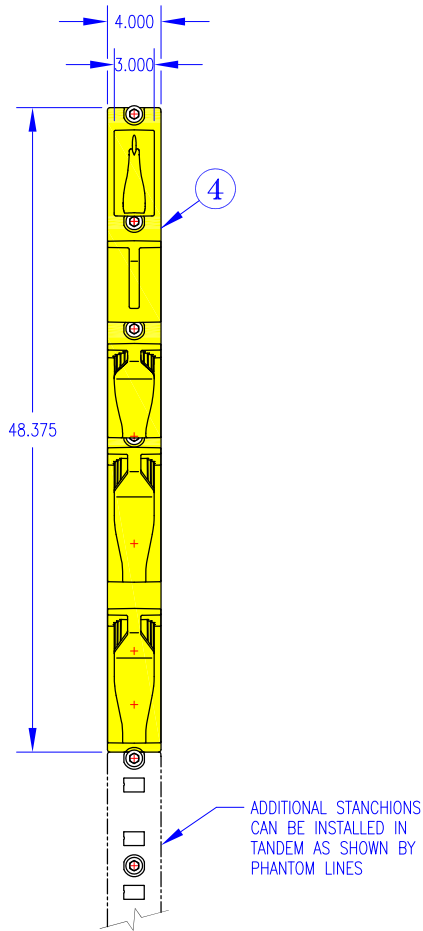
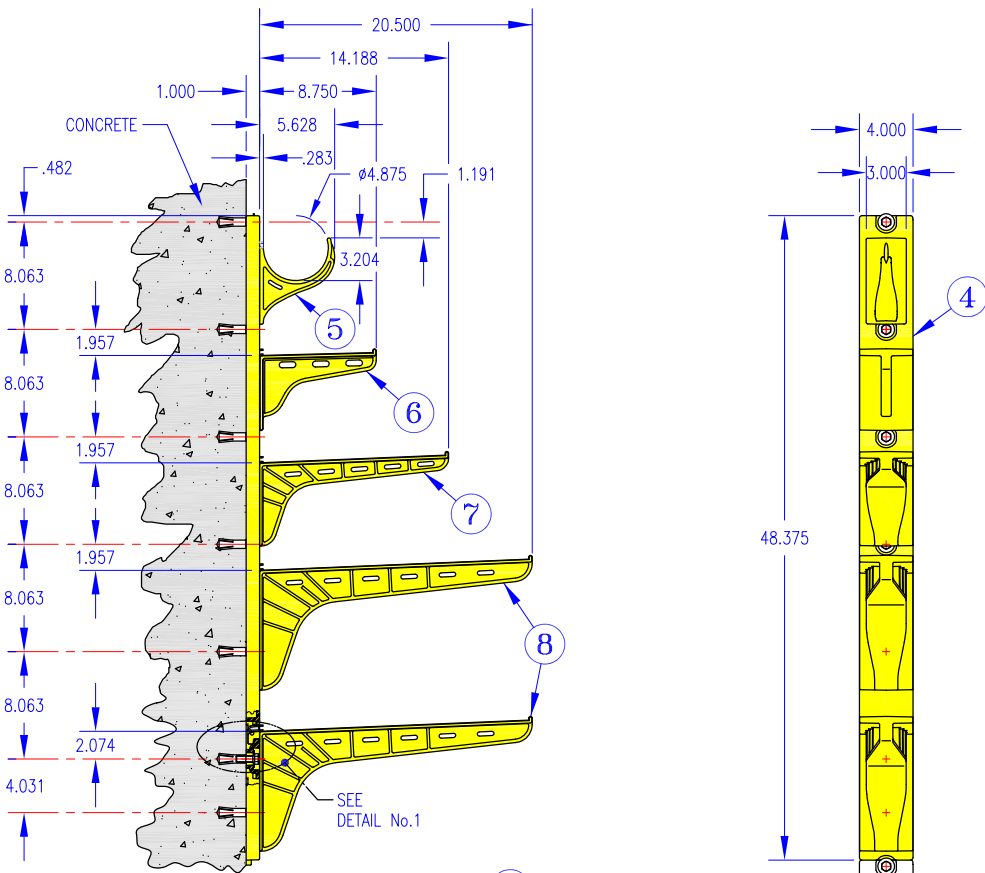

GENERAL INSTALLATION GUIDELINES

1. BE SURE THE SURFACE OF THE CONCRETE WALL IS SMOOTH, FLAT AND PLUMB.
2. **IT IS IMPERATIVE TO INSTALL A FASTENER SET IN EVERY ELONGATED STANCHION HOLE.**
3. INSTALL EACH DROP-IN ANCHOR AS SHOWN ON THIS DRAWING AND AS DESCRIBED BELOW:
 - A. DRILL A 5/8" DIAMETER HOLE 2" DEEP.
 - B. BLOW OUT HOLE.
 - C. DRIVE ANCHOR FLUSH TO 1/16" BELOW SURFACE OF CONCRETE.
 - D. EXPAND ANCHOR WITH FRT-112 SETTING TOOL. ANCHOR IS PROPERLY SET WHEN SHOULDER OF SETTING TOOL IS FLUSH WITH THE TOP OF ANCHOR.
4. INSTALL THE FLAT WASHER AND TIGHTEN THE CAP SCREW JUST ENOUGH TO ATTAIN A SNUG FIT. AVOID HIGH SCREW TORQUE WHICH INDUCES COMPRESSIVE STRESS.
5. AFTER ASSEMBLING THE ARMS TO THE STANCHION, TAP THE ARM DOWN WITH A LIGHT MALLET BLOW. THE LIGHT MALLET BLOW WILL FULLY SEAT AND LOCK ARM IN PLACE.
6. INSTALL OPTIONAL HDL LOCK BY PLACING THE LOCK ON THE ARM WITH THE LOCKING BARBS UP. PUSH THE LOCK INTO THE RECTANGULAR HOLE IN THE STANCHION. WHEN THE STOP FLANGES ON THE LOCK HIT THE STANCHION, THE LOCK WILL CLICK INTO PLACE. SEE DETAIL No.1 AT LEFT.

NOTES:

1. THE ANCHOR ARRANGEMENT SHOWN ON THIS INSTALLATION DRAWING ALLOWS FOR COMPLETE VARIABILITY OF ARM SIZE & LOCATION OF ARM ON STANCHION.
2. SEE UDI "MOUNTING HARDWARE" CATALOG SHEET (FORM 120292AD) FOR ANCHOR LOAD CAPACITY, GENERAL ANCHOR NOTES AND HEX HEAD CAP SCREW NOTES.
3. SEE UDI "TECHNICAL DATA" CATALOG SHEET (FORM 111391AE) FOR LOAD CARRYING CAPACITY.
4. SEE UDI "GUIDE SPECIFICATION" (FORM 123191AK) FOR GENERAL SPECIFICATIONS ON THE HEAVY DUTY NON-METALLIC CABLE RACK.

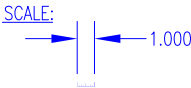

US PATENT 7,140,500
CANADIAN PATENTS
2,486,904 & 2,640,899.
OTHER PATENTS MAY
APPLY OR BE PENDING.



HEAVY DUTY NON-METALLIC CABLE RACK
Installation Details For 1 Ea. CR48-B Stanchion With 1 Ea. 4.9HDS Saddle,
1 Ea. RA08, 1 Ea. RA14-LP & 2 Ea. RA20-LP Arms Using Drop-In Anchors

| | | | |
|--------------------|------------------------|--------------------------|-----------------------|
| SCALE: See At Left | DESIGNED BY: Don McCoy | DRAWN BY: Alan Armstrong | CHECKED BY: Don McCoy |
| DATE: 9-11-18 | APPROVED BY: | REVISION: | |

1st Designed For TYPICAL INSTALLATION OF CABLE RACKS

UNDERGROUND DEVICES, INC. DRAWING NUMBER: **90-10514**
NORTHBROOK, ILLINOIS 60062 - PHONE: (847) 205-9000 PAGE 1 OF 1